

# Cast Steel (WCB) Gate Valve



**ASA 150#**

## TECHNICAL DATA

**Manufacturing Std. : API 600, BS 1414.**

**Testing & Insp. Std. : API 598.**

**Face to Face : As per ANSI B 16.10**

**End Connection : Flanged as per ANSI B 16.5 RF.**

SR. NO.	NOMENCLATURE	MATERIAL
1	BODY	C.S. (ASTM A 216 Gr. WCB)
2	BONNET	C.S. (ASTM A 216 Gr. WCB)
3	SEAT RING	SS 410.
4	WEDGE	SS 410.
5	SPINDLE	SS 410.
6	GLAND FLANGE	C.S. (ASTM A 216 Gr. WCB)
7	YOKE NUT	M.S.
8	GASKET	GRAPHITE ASBESTOS / SPIRAL.
9	EYE BOLT & NUT	CARBON STEEL.
10	STUD & NUT	ASTM A 193 Gr. B7 / 194 Gr. 2H.
11	GLAND PACKING	GRAPHOIL RING (GRAPHITE ASBESTOS).
12	BACK SEAT	SS 410.
13	HAND WHEEL	SG IRON.
14	HAND WHEEL NUT	M.S.



ASA 150#								
SIZE		A	B	C	D	E	F	G
INCH	M.M.	Fl TO Fl	(RF)	(F.T.)	(OD)	No. of Hole	(PCD)	Hole Dia
1"	25	127	51	11	108	04	79	16
1.1/2"	40	165	73	14	127	04	98	16
2"	50	178	92	16	152	04	121	19
2.1/2"	65	191	105	17	178	04	140	19
3"	80	203	127	19	190	04	152	19
4"	100	229	157	24	229	08	190	19
5"	125	254	186	24	254	08	216	22
6"	150	267	216	25	280	08	241	22
8"	200	292	270	29	343	08	298	22
10"	250	330	324	30	406	12	362	25
12"	300	356	381	32	483	12	432	25
14"	350	381	413	35	533	12	477	28
16"	400	406	470	37	597	16	540	28

SERVICE RATING & TEST PRESSURE				
CLASS	WORKING PRESSURE	TEMPERATURE (MAX)	HYD. TEST PRESS.	
			BODY	SEAT
150#	10KG/CM2	300 DEG. C.	28KG/CM2	20KG/CM2

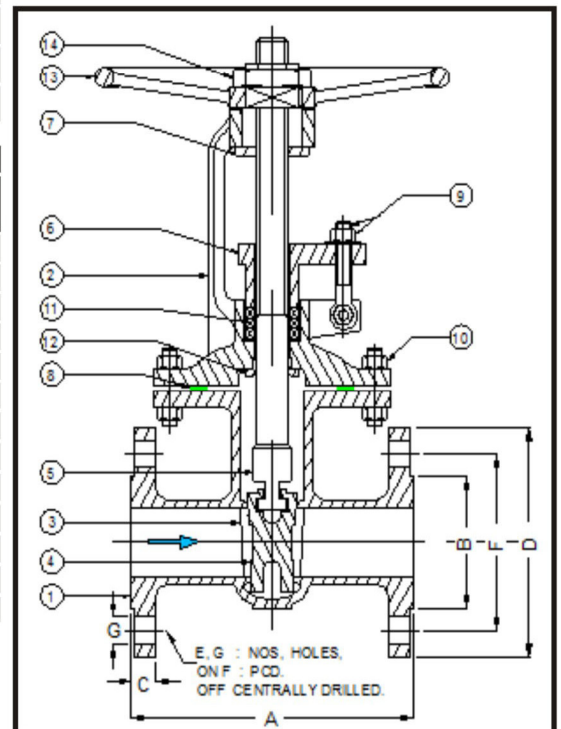

\*All dimensions are in M.M.

Manufactured by :- **VALSON VALVES MFG. CO. - AHMEDABAD. (GUJ.)**

Visit us : [www.valsonvalves.com](http://www.valsonvalves.com)